

IS : 884 – 1985
(Reaffirmed 2005)

REAFFIRMED

2010

Indian Standard

SPECIFICATION FOR
FIRST-AID HOSE-REEL FOR FIRE FIGHTING

(First Revision)

First Reprint JUNE 2008
(Including Amendment No. 1 & 2)

UDC 614.843.6

© Copyright 1985

BUREAU OF INDIAN STANDARDS
MANAK BHAVAN, 9 BAHADUR SHAH ZAFAR MARG
NEW DELHI 110002

AMENDMENT NO. 3 DECEMBER 2008
TO
IS 884 : 1985 SPECIFICATION FOR FIRST-AID
HOSE-REEL FOR FIRE FIGHTING

(First Revision)

[Page 4, clause 2.1(g)] — Substitute 'shut' for 'shutt'.

(Page 7, clause 5.3.1):

a) In the title substitute '*Impact Resistance Test (Strength Test)*' for '*Impact Test*'.

b) Insert the following after first sentence:

'The length of the steel bridge shall be such that it extends by at least 10 mm on either side of the two round plates when kept on them. The steel bridge shall have two numbers of suitable parallel grooves, say 10 mm wide and 5 mm deep to ensure that the bridge shall not slip and fall down during the conduct of Impact resistance test.'

c) Substitute '*5.4.1*' for '*5.2.1*' in line 6.

d) Insert the following before last sentence:

'As a result of single impact due to free fall of 25 kg mass from a height of 300 mm the reel shall not get deformed and the distance between the parallel round plates shall not change.'

(Page 7, clause 5.3.2):

a) In the title, substitute '*Load Resistance Test*' for '*Load Test*'.

b) Substitute the following for the existing first sentence:

'A mass of 80 kg is suspended using steel wire ropes on the top edge of front round plate (with clamps) constituting one side of the hose reel.'

c) Substitute '*5.4.1*' for '*5.2.1*' in line 4.

Amend No. 3 to IS 884 : 1985

(Page 7, clause 5.4.1, line 2) — Substitute '0.7 ± 0.01 MPa' for '7 ± 0.1 bar'.

(Page 7, clause 5.4.1) — Add the following new clauses:

5.5 Swinging — In case of Type A Hose Reel swivel joint(s) shall be incorporated in the construction to enable the users to swing the hose reel by 180 degrees while pulling the hose in either direction.

5.6 Reel Action — In case of both Type A and Type B hose reels it shall be possible to easily and smoothly unwind the hose by pulling the hose end having nozzle fitted to it. Also it shall be easy to wind up the hose when done with.'

(Page 7, clause 6) — Add the following new clauses and renumber the existing clauses:

6 WORKMANSHIP — The construction of the hose reel shall be such that there shall be no sharp end jagged edges or surface, etc, so as to cause physical injury to the personnel handling the hose reel.

7 PAINTING — All the internal and external surface of the ferrous components of the hose reel shall be coated with epoxy polyester powder to 50 μ, Min thickness to protect it against rusting. The colour of the powder coating shall be fire red conforming to Shade No. 536 or 538 of IS 5.'

(Page 8, Fig. 3, Captions) — Substitute 'DETAIL OF IMPACT REISTANCE TEST ON TYPE A HOSE REEL' for 'DETAIL OF IMPACT TEST'.

(Page 9, Fig. 4, Captions) — Substitute 'DETAIL OF LOAD RESISTANCE TEST ON TYPE A HOSE REEL' for 'DETAIL OF LOAD TEST'.

(CED 22)

AMENDMENT NO. 2 MAY 2006
TO
IS 884 : 1985 SPECIFICATION FOR FIRST-AID
HOSE-REEL FOR FIRE FIGHTING

(First Revision)

[Page 4, clause 3.1, Table 1, Sl No. (v)] — Substitute the following for the existing:

(3)

(4)

v) Hose reel tubing:

a) Rubber

IS 444 : 1987||

b) Thermoplastic hoses

IS 12585 : 1988§§

||Specification for general purpose rubber water hose (*fourth revision*).

§§Specification for thermoplastic hoses (textile reinforced) for water — General purpose.

(CED 22)

AMENDMENT NO. 1 JULY 1987

TO

IS:884-1985 SPECIFICATION FOR FIRST-AID
HOSE-REEL FOR FIRE FIGHTING

(First Revision)

(Page 4, Table 1, col 3 and 4) - Add the following matter under col 3 and 4:

Sl No.	Material	Conforming to Indian Standard
(1)	(2)	(3)
i)	Mild steel sheet Aluminium sheet	IS:513-1973+ IS:737-1974‡
ii)	Aluminium alloy Mild steel sheet	A-8 WP of IS:617-1975* IS:513-1973+
iii)	Cast Iron	IS:210-1978§§

'§§§Specification for grey iron castings (third revision)'

(Page 7, clauses 5.2 and 5.2.1) - Substitute the following for the existing clauses:

'5.2 Resistance to Leakage - The complete assembly shall be capable of withstanding the hydrostatic pressure test of 21 kgf/cm² for 5 min.'

(Page 7, clause 5.4) - Add the following sentence at the end of the existing clause:

'This shall be a type test'.

Indian Standard

SPECIFICATION FOR

FIRST-AID HOSE-REEL FOR FIRE FIGHTING

(First Revision)

Fire Fighting Sectional Committee, BDC 22

<i>Chairman</i>	<i>Representing</i>
SHRI G. B. MENON	Gujarat Electricity Board, Vadodara
<i>Members</i>	
SHRI A. N. AHLUWALIA	The Institution of Fire Engineers (India), New Delhi
SHRI B. R. MEHTA (<i>Alternate</i>)	
SHRI S. R. BANSAL	Steel Authority of India (Bokaro Steel Plant), Bokaro Steel City
SHRI B. L. CHAUDHRY	Oil and Natural Gas Commission, Dehra Dun
SHRI B. K. SIPPY (<i>Alternate</i>)	
SHRI K. K. DAS GUPTA	West Bengal Fire Services, Government of West Bengal, Calcutta
DEPUTY INSPECTOR GENERAL (RPSF)	Ministry of Railways
ASSISTANT SECURITY OFFICER (FIRE), NORTHERN RAILWAY (<i>Alternate</i>)	
SHRI V. P. DEWAN	Ministry of Defence (DGI)
LT-COL V. R. BANAHATI (<i>Alternate</i>)	
SHRI S. K. DHRI	Municipal Corporation of Delhi (Delhi Fire Service), Delhi
SHRI R. K. BHARDWAJ (<i>Alternate</i>)	
SHRI R. R. DHOBLEY	Bhabha Atomic Research Centre, Bombay
DIRECTOR	Home Department (Fire Service), Government of Tamil Nadu, Madras
DEPUTY DIRECTOR (<i>Alternate</i>)	
DIRECTOR GENERAL OF FIRE SERVICES	Home (Police) Department, Government of Andhra Pradesh, Hyderabad
DEPUTY DIRECTOR (FIRE SERVICES) (<i>Alternate</i>)	

(Continued on page 2)

© Copyright 1985

BUREAU OF INDIAN STANDARDS

This publication is protected under the *Indian Copyright Act (XIV of 1957)* and reproduction in whole or in part by any means except with written permission of the publisher shall be deemed to be an infringement of copyright under the said Act.

(Continued from page 1)

<i>Members</i>	<i>Representing</i>
FIRE ADVISER	Ministry of Home Affairs
SHRI A. K. GUPTA	Central Building Research Institute (CSIR), Roorkee
SHRI J. S. JAMSHEDJI	Steelage Industries Limited (Minimax Division), Bombay
SHRI C. GHANARAJ (Alternate)	
SHRI P. KHANNA	Jaya Shree Textiles and Industries, Rishra
SHRI S. N. KUNDU	Fire and Safety Appliances Co, Calcutta
MANAGING DIRECTOR	Avon Services (Production & Agencies) Pvt Ltd, Bombay
TECHNICAL EXECUTIVE (Alternate)	
BRIG S. A. MOHILE	Ministry of Defence (R & D)
SHRI A. K. SURI (Alternate)	
SHRI M. MUKHERJI	Steel Authority of India Ltd (Rourkela Steel Plant), Rourkela
SHRI C. D. SHARMA (Alternate)	
SHRI V. B. NIKAM	Municipal Corporation of Greater Bombay (Bombay Fire Brigade), Bombay
SHRI P. N. PANCHAL	Central Industrial Security Force (Ministry of Home Affairs), New Delhi
SHRI P. H. SETHNA	Kooverji Devshi and Co (P) Ltd, Bombay
SHRI N. T. PANJWANI (Alternate)	
SHRI R. C. SHARMA	Directorate General of Supplies and Disposals, New Delhi
SHRI D. S. NARESH (Alternate)	
SHRI D. K. SIRKAR	Synthetics and Chemicals Ltd, Bareilly
SHRI CHANDRAKANT M. SHAH	Zenith Fire Services, Bombay
SHRI M. H. SHAH (Alternate)	
SHRI J. V. SHAH	Newage Industries, Surendranagar (Gujarat)
SHRI B. J. SHAH (Alternate)	
SHRI TARIT SUR	Surex Production and Sales (P) Ltd, Calcutta
SHRI SUSHIL KUMAR	Directorate General of Technical Development, New Delhi
SHRI J. N. VAKIL	Tariff Advisory Committee, Bombay
SHRI K. RAVI (Alternate)	
SHRI S. VENKASWAMY	Directorate General of Civil Aviation, New Delhi
SHRI B. V. WAGLE	Urban Development, Public Health and Housing Department, Government of Maharashtra, Bombay
SHRI V. H. MADKAIKAR (Alternate)	
SHRI G. RAMAN, Director (Civ Engg)	Director General, ISI (Ex-officio Member)

Secretary
SHRI K. M. MATHUR
Joint Director (Civ Engg), ISI

(Continued on page 10)

Indian Standard
SPECIFICATION FOR
FIRST-AID HOSE-REEL FOR FIRE FIGHTING
(*First Revision*)

0. FOREWORD

0.1 This Indian Standard (First Revision) was adopted by the Indian Standards Institution on 16 May 1985, after the draft finalized by the Fire Fighting Sectional Committee had been approved by the Civil Engineering Division Council.

0.2 Hose-reels are recommended for use in fixed installations for various premises and also as an equipment to the fire engines. It is an equipment consisting of the reel, water inlet pipe, shut off nozzle, stop valve with hose reel tubing and provide a most effective fire fighting facility. This standard was first published in 1969. This revision has been prepared so as to cover hose reel in addition to fixed installations for the use in the fire engine besides making the requirements specific and up to date.

0.3 For the purpose of deciding whether a particular requirement of this standard is complied with, the final value, observed or calculated expressing the result of a test or analysis, shall be rounded off in accordance with IS: 2-1960*. The number of significant places retained in the rounded off value should be the same as that of the specified value in this standard.

1. SCOPE

1.1 This standard lays down the requirements for materials, constructional details and tests for first-aid hose reels intended for installation in buildings and for mounting on fire engine.

2. GENERAL

2.1 The hose reel shall consist of following components:

- a) Hub,
- b) Two sides,

*Rules for rounding off numerical values (*revised*).

- c) Swivel joint,
- d) Pipe with fitting,
- e) Wall bracket,
- f) Hose reel,
- g) Nozzle with shutt off arrangement, and
- h) Stop valve.

3. MATERIALS

3.1 The details of materials for the various components are given in Table 1.

TABLE 1 DETAILS OF MATERIALS FOR VARIOUS COMPONENTS OF HOSE REEL

Sl No.	COMPONENTS	MATERIAL	CONFORMING TO INDIAN STANDARD
(1)	(2)	(3)	(4)
i)	Hub	Aluminium alloy	A-8 WP of IS : 617-1975*
ii)	Sides	Mild steel sheet	IS : 513-1973†
		Aluminium sheet	IS : 737-1974‡
iii)	Wall bracket	Mild steel	IS : 513-1973†
iv)	Swivel joint	Leaded tin bronze	Grade LTB-2 of IS : 318-1981§
v)	Hose reel tubing	Rubber	IS : 444-1980
vi)	Nozzle with branch pipe and coupling	—	IS : 8090-1976¶
vii)	Stop valve	—	IS : 778-1979**
viii)	Pipe with fitting	Steel	IS : 1239 (Part 1)-1979†† IS : 1239 (Part 2)-1969‡‡

*Specification for aluminium and aluminium alloy ingots and castings for general engineering purposes (*second revision*).

†Specification for cold rolled carbon steel sheets (*second revision*).

‡Specification for wrought aluminium and aluminium alloys, sheet and strip (for general engineering purposes) (*second revision*).

§Specification for leaded tin bronze ingots and castings (*second revision*).

||Specification for rubber water hose (*third revision*).

¶Specification for coupling, branch pipe, nozzle used in hose reel tubing for fire fighting.

**Specification for copper alloy gate, globe and check valves for water works purposes (*third revision*).

††Specification for mild steel tubes, tubulars and other wrought steel fittings : Part 1-1979 Mild steel tubes (*fourth revision*).

‡‡Specification for mild steel tubes, tubulars and other wrought steel fittings : Part 2-1969 Mild steel tubulars and other wrought steel pipe fittings (*second revision*).

4. TYPES

4.1 The reel shall be made in two types as below :

Type A — Swinging (180°) wall mounting type (*see Fig. 1*).

Type B — Horizontal type used for installation on fire engines (*see Fig. 2*).

5. REQUIREMENT

5.1 The essential dimensions of the two types are given in Fig. 1 and 2. It shall be designed so as to comply with the requirements given in 5.2 to 5.4.

5.2 Resistance to Leakage — The complete assembly shall be capable of operating at 10 bar maximum working pressure without leakage, when tested in accordance with 5.2.1.

5.2.1 Connect the hose reel to a water supply at a pressure of 10 bar and with the hose fully wound into the drum. Close the nozzle for 5 min, subjecting the reel to a pressure of 10 bar. Unwind the hose completely, maintaining the pressure of 10 bar for a further 5 min.

5.3 Strength

5.3.1 Impact Test — Rest a steel bridge 100 × 25 mm cross-section centrally across the two reel side plates vertically above the centre line of the spindle. Mount a steel cylindrical hammer of 25 kg mass and with flat faces in guides above the steel bridge so that it falls freely through a height of 300 mm to strike the steel bridge midspan between the two plates. After a single impact, test the reel in accordance with 5.2.1. The arrangement of the impact test is shown in Fig. 3. This shall be a type test.

5.3.2 Load Test — Suspend a mass of 80 kg from the spindle in case of Type A reels and from the point midway between the supports, in case of Type B. Remove the mass after 72 h and test the reel in accordance with 5.2.1. The arrangement of the load test is shown in Fig. 4. This shall be a type test.

5.4 Range and Water Flow Rate — When tested in accordance with 5.4.1, the water flow rate shall be not less than 24 l/min and the range of the jet shall be not less than 6 m.

5.4.1 Range and Water Flow Test — Measure the range and water flow rate of the reel at inlet pressure of 7 ± 0.1 bar. The range is the distance from the nozzle to the point on the ground beyond which 50 percent of the discharge falls. Measure the range with the nozzle 1 m above floor level at an angle of elevation to give maximum range.

6. MARKING

6.1 Each first-aid hose-reel shall be clearly and permanently marked with the following information:

- a) Manufacturer's Name or trade-mark,
- b) Year of manufacture, and
- c) Type of reel.

5

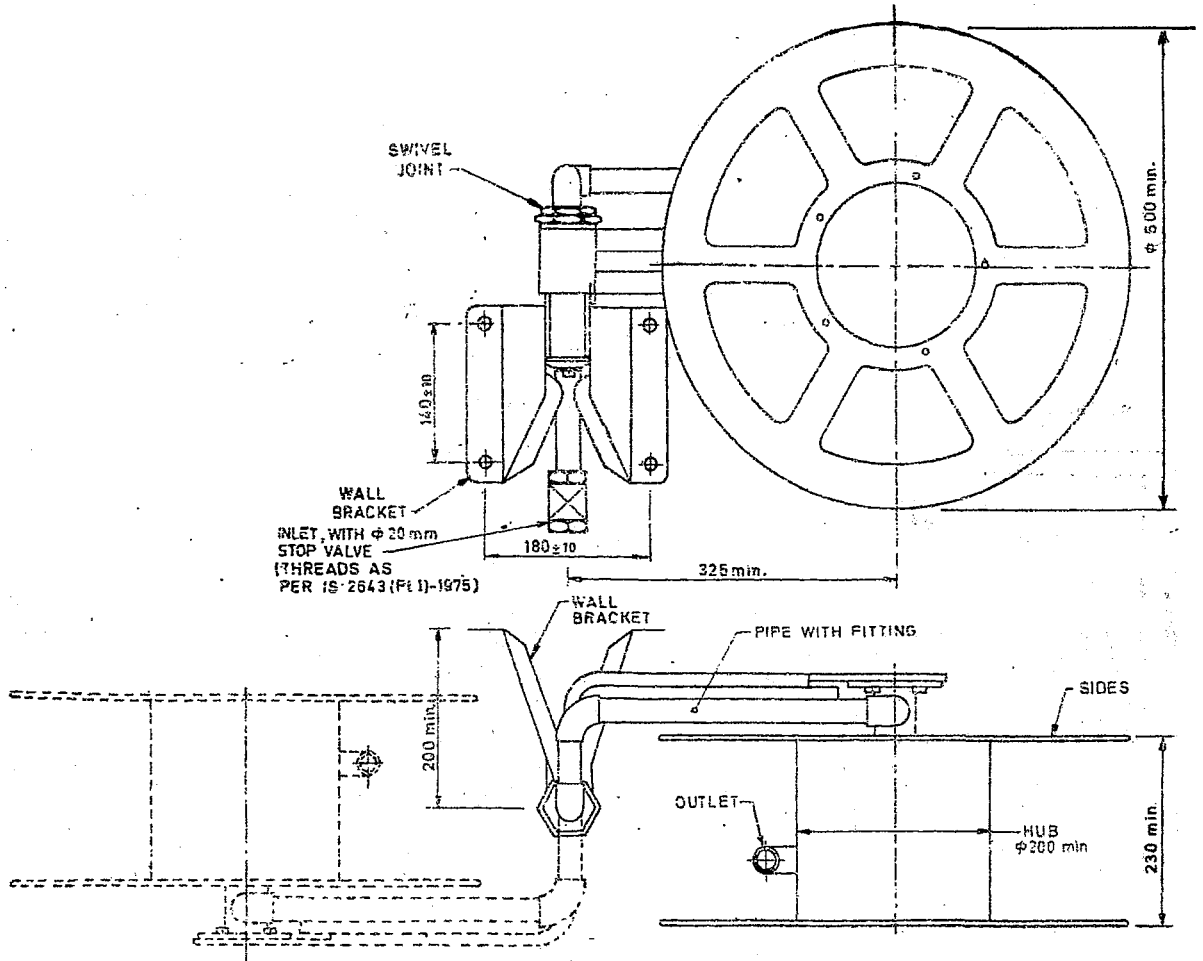

All dimensions in millimetres.
FIG. 1 HOSE REEL SWINGING TYPE

IS : 884 - 1985

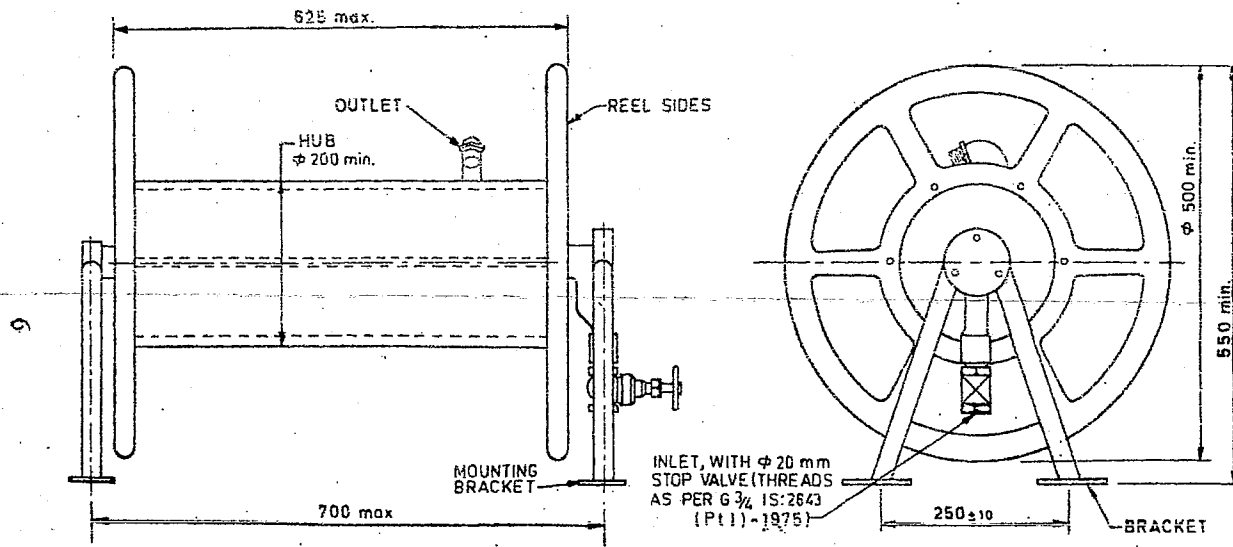

All dimensions in millimetres.

FIG. 2 HOSE REEL HORIZONTAL TYPE

IS : 884 - 1985

6.1.1 The product may also be marked with Standard Mark.

6.1.2 The use of the Standard Mark is governed by the provisions of the Bureau of Indian Standards Act, 1986 and the Rules and Regulations made thereunder. The details of conditions under which the licence for the use of Standard Mark may be granted to manufactures or producers may be obtained from the Bureau of Indian Standards.

7. CRITERIA FOR CONFORMITY

7.1 Each equipment shall be checked for the requirement given in this standard.

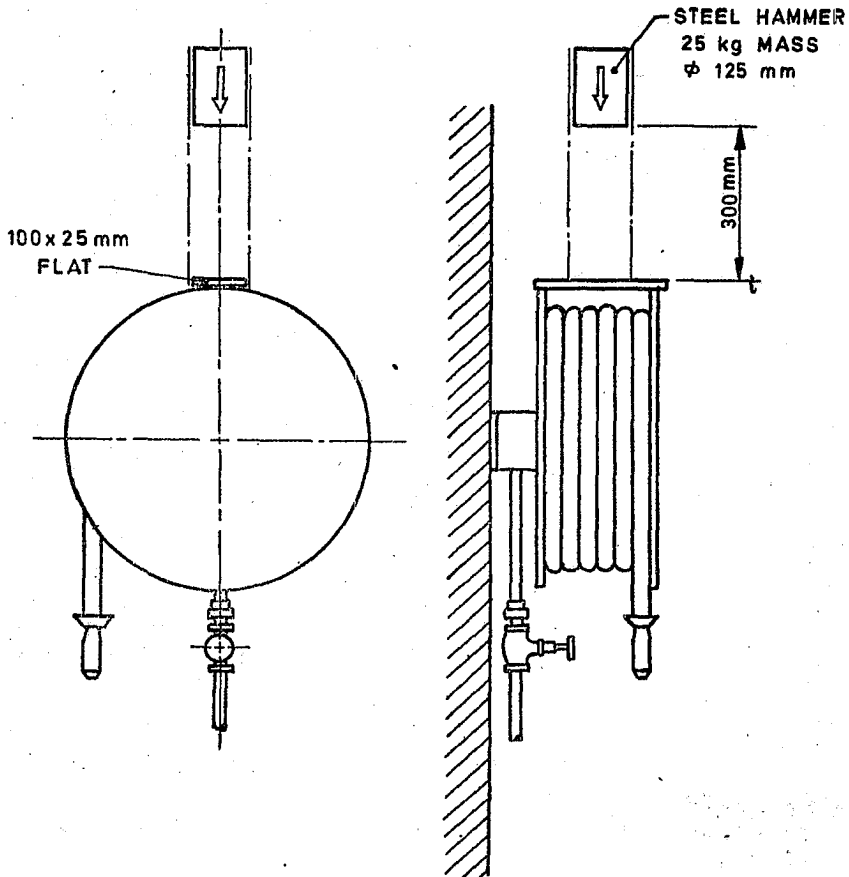

FIG. 3 DETAIL OF IMPACT TEST

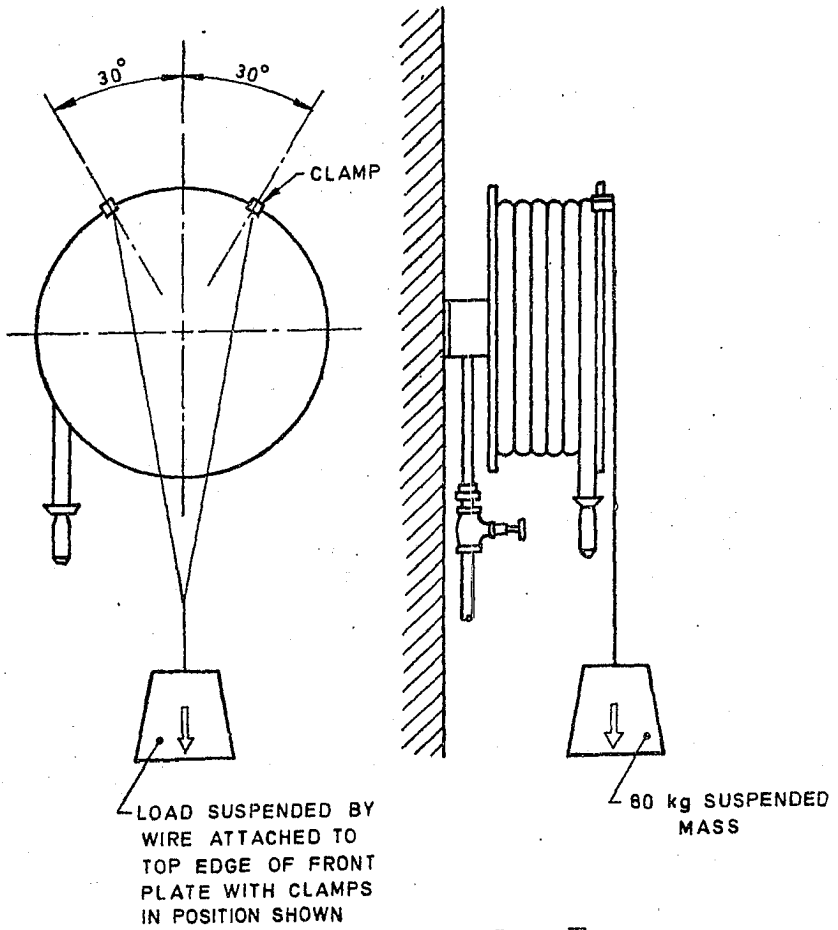

FIG. 4 DETAIL OF LOAD TEST

(Continued from page 2)

Water Fittings for Fire Fighting Purpose Subcommittee, BDC 22 : 1

<i>Convener</i>	<i>Representing</i>
SRI V. P. DEWAN	Ministry of Defence (DGI)
<i>Members</i>	
LT-COL V. R. BANAHATI (<i>Alternate to</i> Shri V. P. Dewan)	
SRI J. K. CHAKRABORTY	Tariff Advisory Committee, Bombay
SRI V. KHURANA (<i>Alternate</i>)	
CHIEF FIRE OFFICER	Municipal Corporation of Delhi (Delhi Fire Service), Delhi
SRI R. K. BHARDWAJ (<i>Alternate</i>)	
FIRE ADVISER	Ministry of Home Affairs
SRI H. S. GAHLAUT	The Institution of Fire Engineers (India), New Delhi
SRI T. L. VERMA (<i>Alternate</i>)	
HYDRAULIC ENGINEER	Municipal Corporation of Greater Bombay (Bombay Fire Service), Bombay
SRI V. B. NIKAM (<i>Alternate</i>)	
SRI P. KHANNA	Jaya Shree Textiles and Industries, Rishra
SRI M. R. KAMAT	Mather & Platt Ltd, Bombay
BRIG S. A. MOHILE	Ministry of Defence (R & D)
SRI A. K. SURI (<i>Alternate</i>)	
SRI H. V. RAO	Engineers India Ltd, New Delhi
SRI K. V. BHARDWAJ (<i>Alternate</i>)	
SRI J. V. SHAH	Newage Industries, Surendranagar (Gujarat)
SRI B. J. SHAH (<i>Alternate</i>)	
SRI J. R. SHAH	Laxmi Sprinklers, Bombay
SRI H. J. NEGANDEHI (<i>Alternate</i>)	
SRI P. H. SETHNA	Kooverji Devshi & Co Pvt Ltd, Bombay
SRI N. T. PANJWANI (<i>Alternate</i>)	

BUREAU OF INDIAN STANDARDS

Headquarters:

Manak Bhavan, 9 Bahadur Shah Zafar Marg, NEW DELHI 110002

Telephones: 23230131, 23233375, 23239402

Fax: 91+011 23239399, 23239382

E-Mail : info@bis.org.in

website : <http://www.bis.org.in>

Central Laboratory:

Plot No. 20/9, Site IV, Sahibabad Industrial Area, SAHIBABAD 201010

Telephone

277 0032

Regional Offices:

Central : Manak Bhavan, 9 Bahadur Shah Zafar Marg, NEW DELHI 110002

2323 7617

*Eastern : 1/14 CIT Scheme VII M, V.I.P. Road, Kankurgachi, KOLKATA 700054

2337 8662

Northern : SCO 335-336, Sector 34-A, CHANDIGARH 160022

260 9285

Southern : C.I.T. Campus, IV Cross Road, CHENNAI 600113

2254 1984

†Western: Manakalaya, E9, MIDC, Behind Marol Telephone Exchange, Andheri (East), MUMBAI 400093

2832 9295

Branch Offices:

'Pushpak', Nurmohamed Shaikh Marg, Khanpur, AHMEDABAD 380001

560 1348

Peenya Industrial Area, 1st Stage, Bangalore-Tumkur Road, BANGALORE

839 4955

Commercial-cum-Office Complex, Opp. Dushera Maidan, Arera Colony, Bittan Market, BHOPAL 462016

242 3452

62-63, Ganga Nagar, Unit VI, BHUBANESHWAR 751001

240 3139

5th Floor, Kovai Towers, 44 Bala Sundaram Road, COIMBATORE 641018

221 0141

SCO 21, Sector 12, Faridabad 121007

229 2175

Savitri Complex, 116 G.T. Road, GHAZIABAD 201001

286 1498

53/5 Ward No. 29, R.G. Barua Road, 5th By-lane, Apurba Sinha Path, GUWAHATI 781003

245 6508

5-8-56C, L.N. Gupta Marg, Nampally Station Road, HYDERABAD 500001

2320 1084

Prithavi Raj Road, Opposite Bharat Overseas Bank, C-Scheme, JAIPUR 302001

222 3282

11/418 B, Sarvodaya Nagar, KANPUR 208005

223 3012

Sethi Bhawan, 2nd Floor, Behind Leela Cinema, Naval Kishore Road, LUCKNOW 226001

261 8923

H. No. 15, Sector-3, PARWANOO, Distt. Solan (H.P.) 173220

235 436

Plot No A-20-21, Institutional Area, Sector 62, Goutam Budh Nagar, NOIDA 201307

240 2206

Patliputra Industrial Estate, PATNA 800013

226 2808

Plot Nos. 657-660, Market Yard, Gultkdi, PUNE 411037

2427 4804

'Sahajanand House' 3rd Floor, Bhaktinagar Circle, 80 Feet Road, RAJKOT 360002

237 8251

T.C. No. 2/275 (1 & 2), Near Food Corporation of India, Kesavadasapuram-Ulloor Road, Kesavadasapuram, THIRUVANANTHAPURAM 695004

255 7914

1st Floor, Udyog Bhavan, VUDA, Siripuram Junction, VISHAKHAPATNAM-03

271 2833

*Sales Office is at 5 Chowringhee Approach, P.O. Princep Street, KOLKATA 700072

2355 3243

†Sales Office (WRO) Plot No. E-9, MIDC, Rd No. 8, Behind Telephone Exchange, Andheri (East), Mumbai-400 0093

2832 9295